

Formulate 20' Vertical Curve

FMLT-WV20-02

Formulate™ is a collection of sophisticated, ergonomically designed exhibit booths. Formulate combines state-of-the-art zipper pillowcase dye-sublimated fabric coverings with advanced lightweight aluminum structures to provide unique design, functionality, and style. The excellence of the Formulate line of displays, hanging structures and products is simply unmatched. Stretch fabric graphics are hand-sewn, durable and dry-cleanable.



We are continually improving and modifying our product range and reserve the right to vary the specifications without prior notice. All dimensions and weights quoted are approximate and we accept no responsibility for variance. E&OE. See Graphic Templates for graphic bleed specifications.

features and benefits:

- State-of-the-art 30mm aluminum tubing with push-button connectors
- Frame can also be configured* as a standard 10' backwall (*requires additional 10' graphic purchase)
- Kit includes: one frame, one dye-sublimated zipper pillowcase graphic, stand-off ladder with monitor mount, counter, two OCL and three OCH2 storage cases
- Lifetime hardware warranty against manufacturer defects

dimensions:

Hardware	Graphic
<p>Assembled unit: 232"w x 92.27"h x 24"d</p> <p>Monitor Mount: Max T.V. size is 36" / 40 lbs. Stand-off monitor mount with shelf: 37.4"w x 92.4"h x 29.4"d</p> <p>Approximate weight (includes graphic): 138 lbs / 62.6 kgs</p>	<p>Total visual area: 232"w x 94.5"h 5893mm(w) x 2400mm(h)</p> <p>Stand-off graphic total visual area: Top: 37.4"w x 24.5"h Bottom: 37.4"w x 38.2"h</p> <p>Please be sure to include a 2" bleed around the perimeter.</p>
<p>Shipping</p> <p>Shipping dimensions - ships in 3 cases: 2 OCL cases: 19"l x 19"w x 56"h 1 OCH2 case: 52"l x 30"w x 15"h</p> <p>Approximate shipping weight (with cases): 208 lbs / 94.3 kgs</p>	<p>Refer to related graphic template for more information.</p> <p>Visit: www.exhibitors-handbook.com/graphic-templates</p>

additional information:

Graphic material:
Dye-sublimated zipper pillowcase fabric

Countertop holds max 25 lbs / 11.3 kgs
Monitor mount: max T.V. size is 36" / 40 lbs
*Kit does not include monitor

Table colors:



silver black mahogany natural



www.display-setup-animations.com

Parts Included		
Part Label	Qty	Part Code
1270MM X 30MM TUBE	x12	WV10-01-T1
R2250 (1163MM ARC) CURVED TUBE	x7	WV10-01-T2
30MM CURVED TUBE WITH PART T AND 90B LEFT SIDE	x1	WV10-01-T2-L
30MM CURVED TUBE WITH PART T AND 90B RIGHT SIDE	x1	WV10-01-T2-R
(2)128MM TUBES SWAGED WITH PART TC-30-T	x2	WV10-01-04
(2)128MM TUBES SWAGED WITH PART TC-30-T	x2	WV10-01-T7
(2) 128MM TUBES SWAGED WITH PART TC-30-X	x2	WV10-01-T5
R2250 X 30MM TUBE WITH WELDED SWAGE RIGHT SIDE	x1	WV10-01-T6-PART C
30MM LEG TUBE WITH LEVELING FOOT	x1	WV10-01-T7-V2
(2) 67MM TUBES SWAGED WITH PART TC-30-T AND SPACER	x1	WV20-01-T7
(2) 67MM TUBES SWAGED WITH PART TC-30-X	x1	WV20-01-T2
STEEL PLATE FOR WVC	x2	WVC-PLATE-STD
20' FABRIC GRAPHIC	x1	WV20-01-G

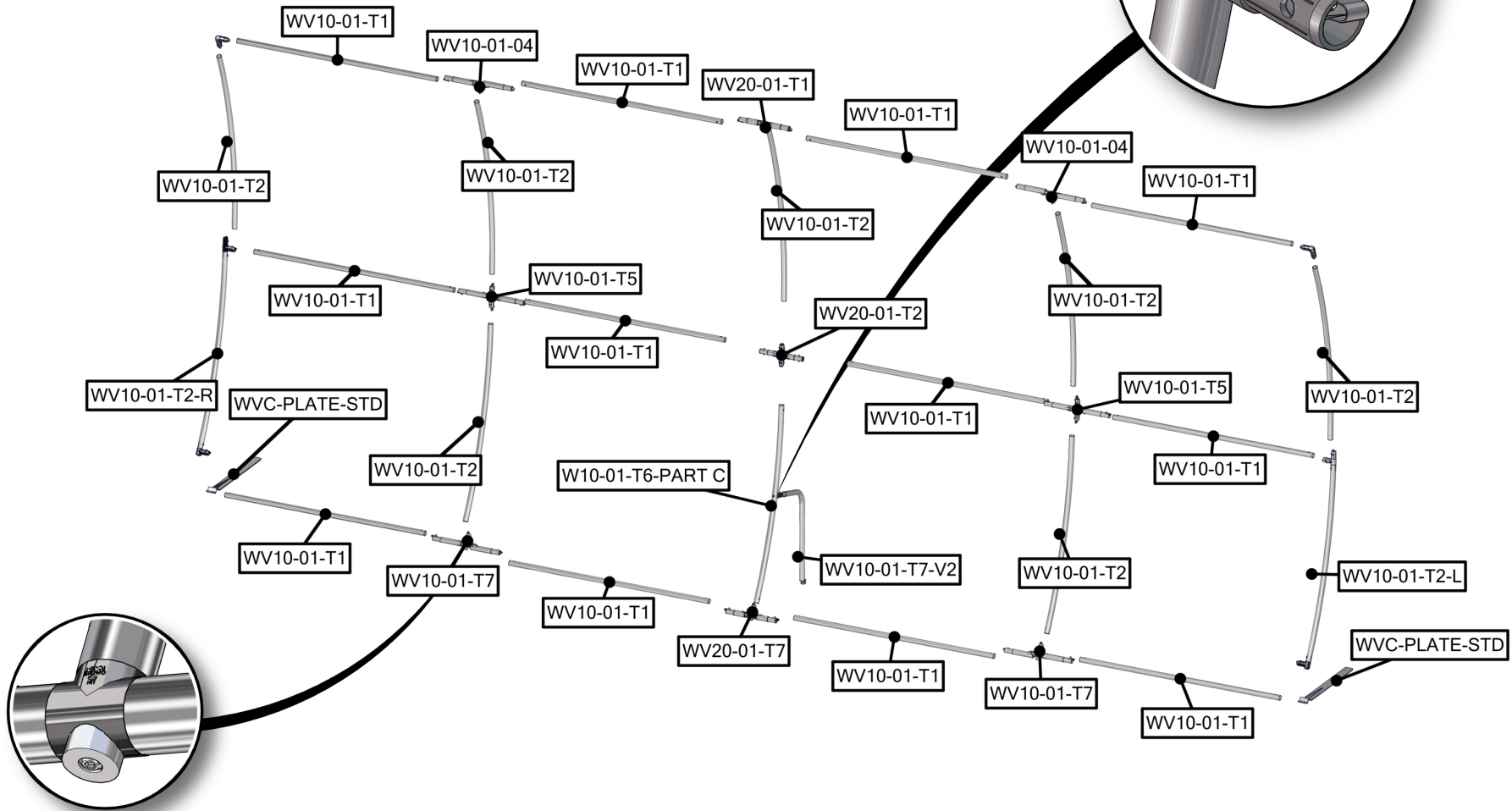
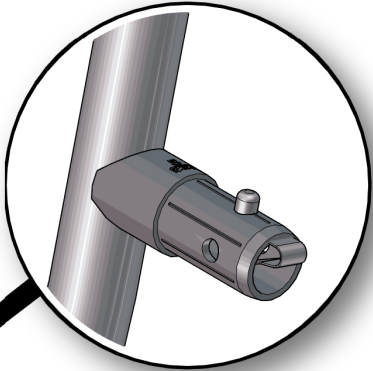

Parts Included		
Part Label	Qty	Part Code
FABRIC GRAPHIC	x1	WV10-01-G
LN114 BOLT	x2	LN114 BOLT
90 DEGREE ELBOW JOINT FOR 30MM TUBING	x2	TC-30-90
1270MM X 30MM TUBE	x6	WV10-01-T1
30MM CURVED TUBE WITH PART T AND 90B LEFT SIDE	x1	WV10-01-T2-L
30MM CURVED TUBE WITH PART T AND 90B RIGHT SIDE	x1	WV10-01-T2-R
R2250 (1163MM ARC) CURVED TUBE	x4	WV10-01-T2
(2) 128MM TUBES SWAGED WITH PART TC-30-T	x2	WV10-01-T7
(2) 128MM TUBES SWAGED WITH PART TC-30-X	x1	WV10-01-T5
STEEL PLATE FOR WVC	x2	WVC-PLATE-STD

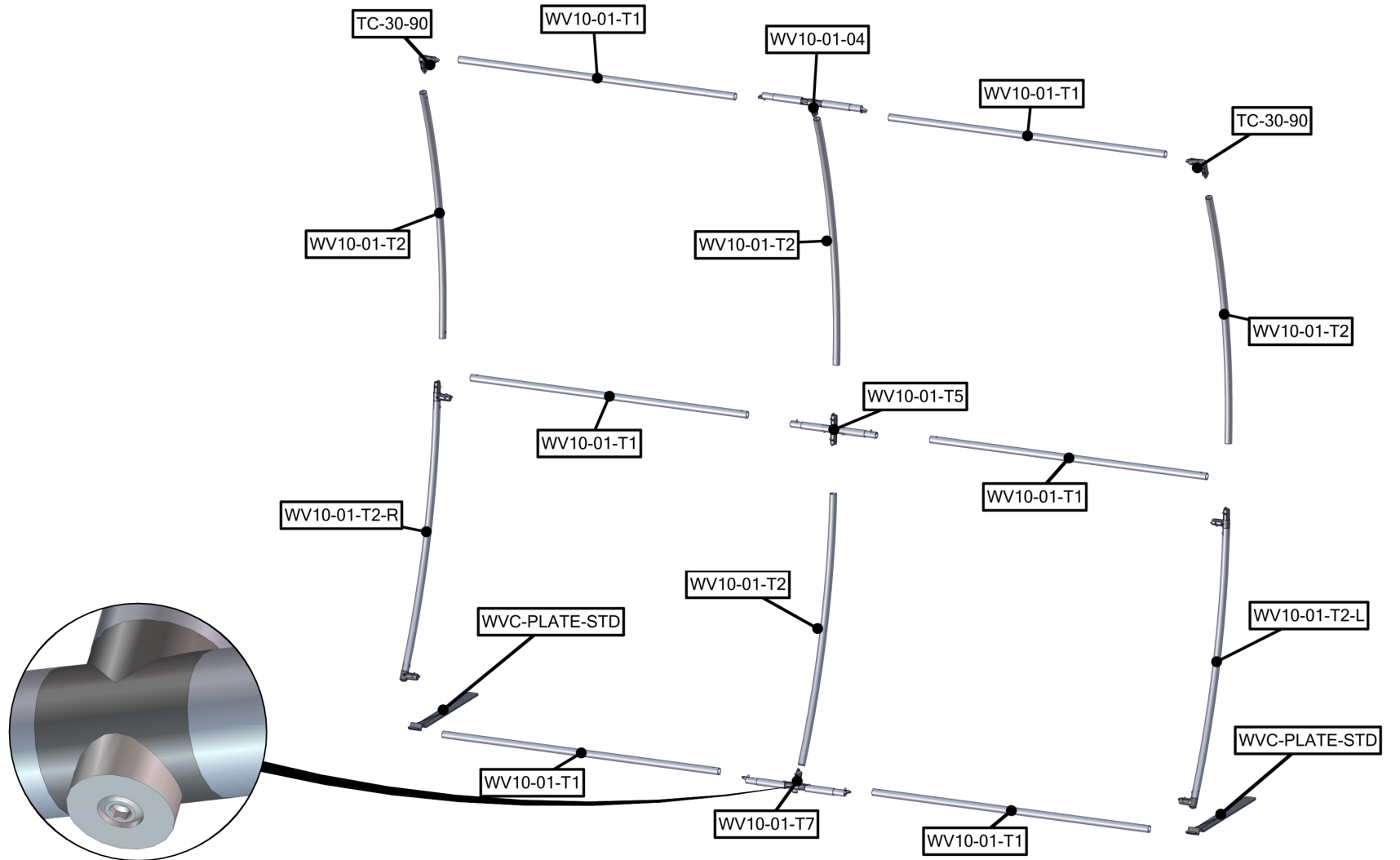

Parts Included		
Part Label	Qty	Part Code
30MM TUBE CLAMP	x2	ACC60
EXPANDING SPIGOT FOR 30MM TUBE	x11	ES-30
FABRIC GRAPHIC BOTTOM	x1	WL04-G-B
FABRIC GRAPHIC TOP	x1	WL04-G-T
MEDIUM MONITOR BRACKET	x1	MM-MB
881MM X 422MM X 30MM COUNTER	x1	WL04-C
30MM CURVED TUBE TOP RIGHT SIDE	x1	RWL04-T1
30MM CURVED TUBE RIGHT SIDE	x1	WRL04-T2
30MM CURVED TUBE LEFT SIDE	x1	WL04-T1
30MM CURVED TUBE LEFT SIDE	x1	WL04-T2
30MM SPREADER TUBE WITH COUNTER SUPPORTS	x1	WL04-T3
30MM BASE TUBE SECTION	x1	WL04-T4
30MM TOP END SECTION	x1	WL04-T6

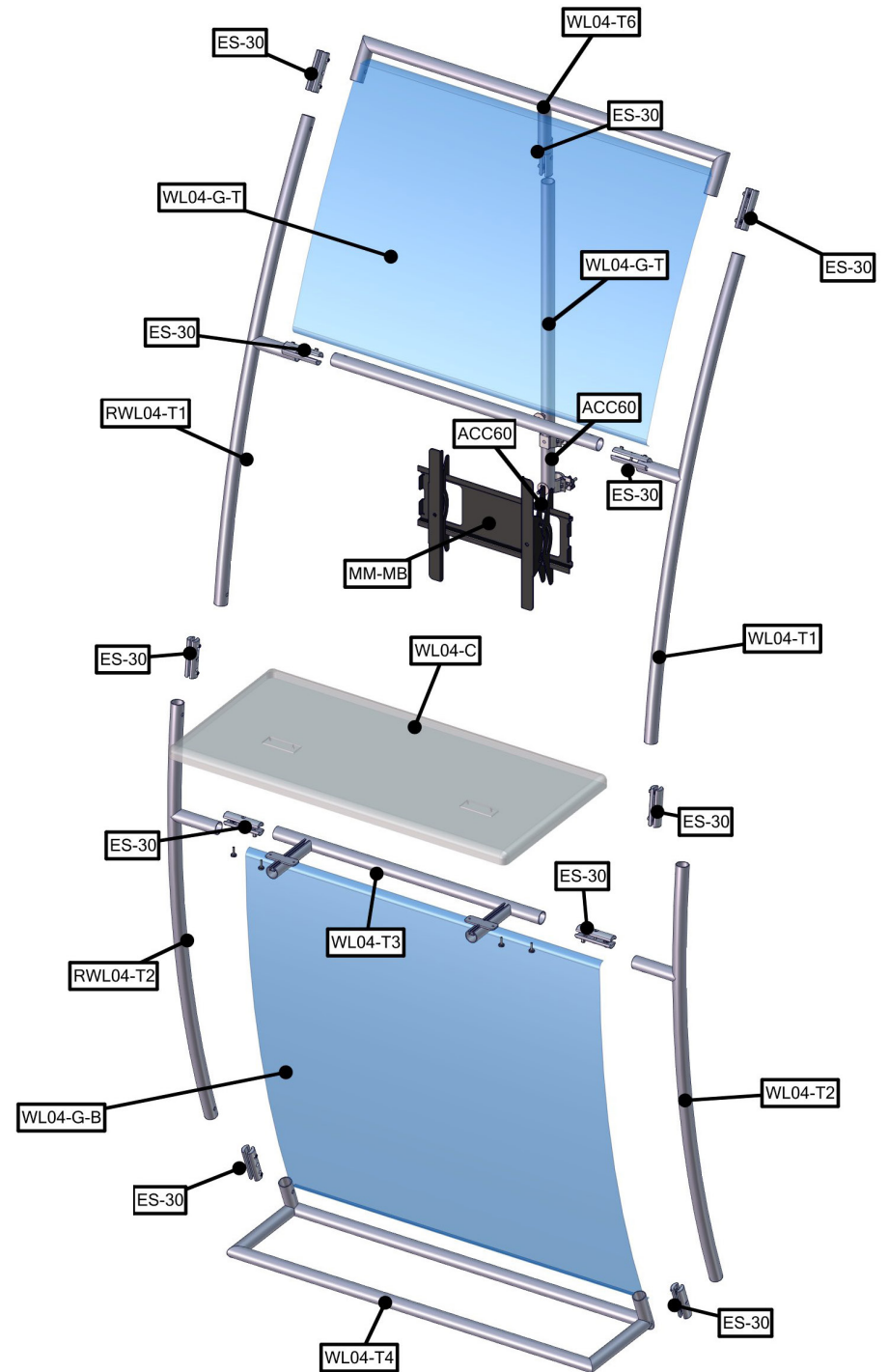

WL04 Frame Assembly:

Assemble unit by laying tubes flat on the floor. Connect the tube rails following the labels by matching number to number. See detailed drawing.

Slide jointer into tubing so hex screw sits in hole on tube. Tighten the hex screw so the jointer separates and tightens against the inside of the tubing, locking the jointer and tubing together.

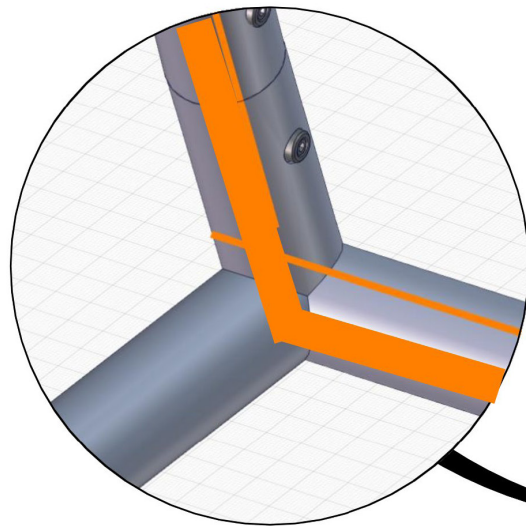
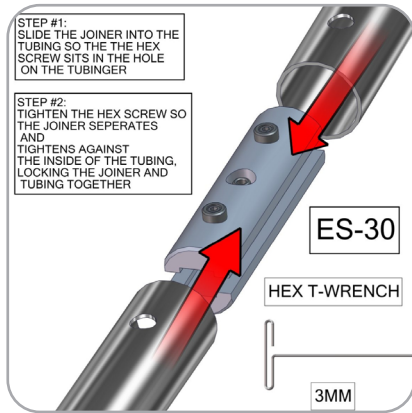

NOTE: TUBES WITH VELCRO ON FACE

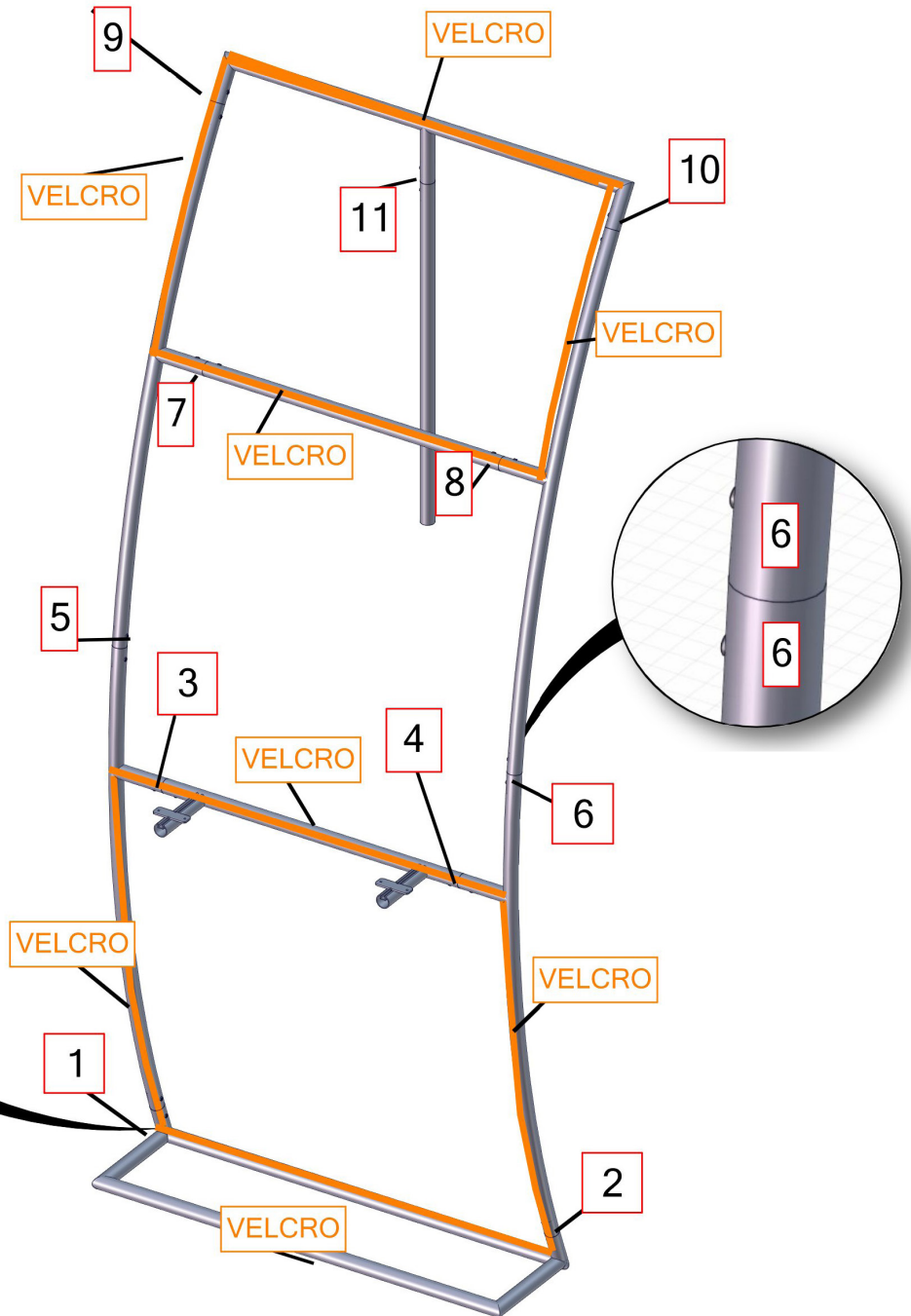

STEP 1: ASSEMBLE FRAME

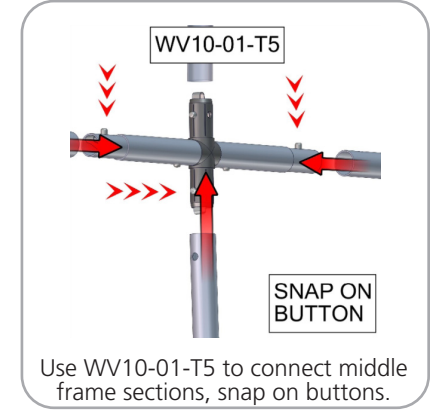
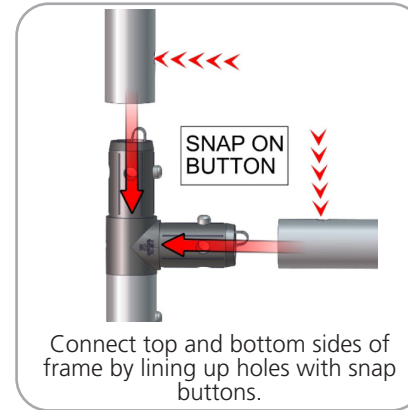
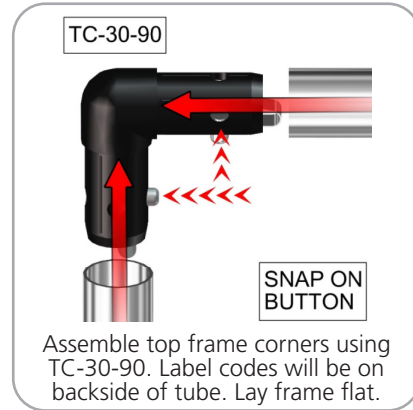
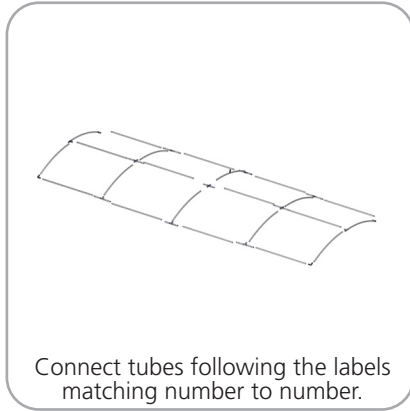

STEP 2: ATTACH FEET



STEP 3: APPLY GRAPHIC

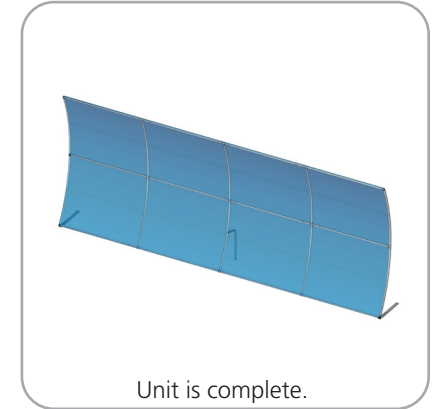
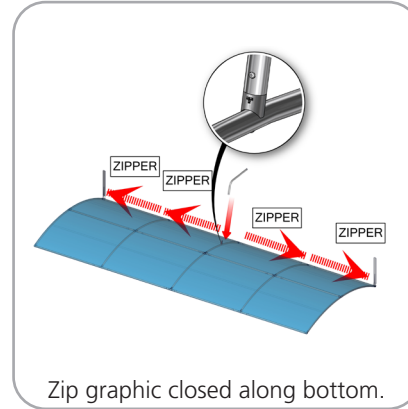
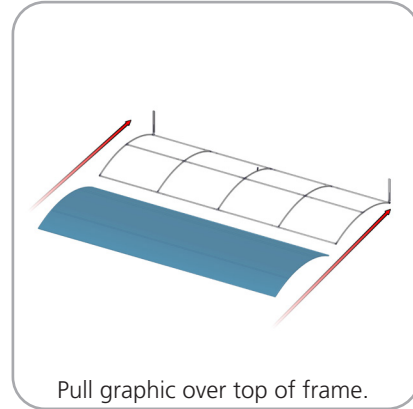

STEP 4: ASSEMBLE LADDER FRAME

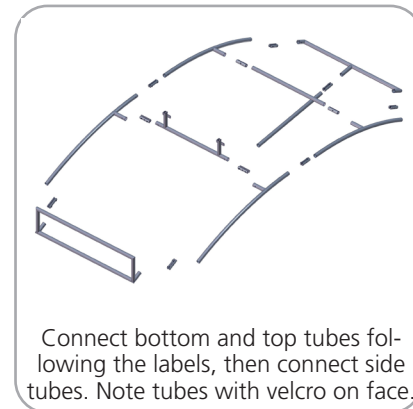
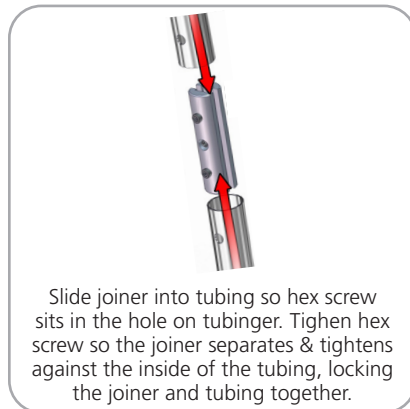

STEP 5: ATTACH GRAPHICS TO LADDER

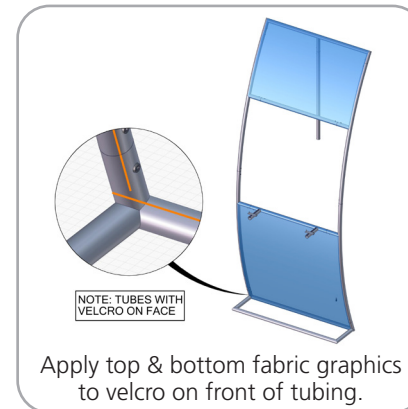

STEP 6: INSTALL MONITOR MOUNT

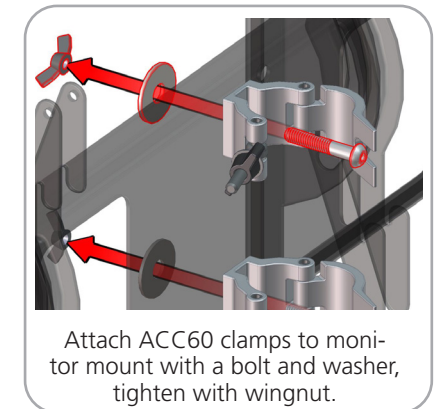

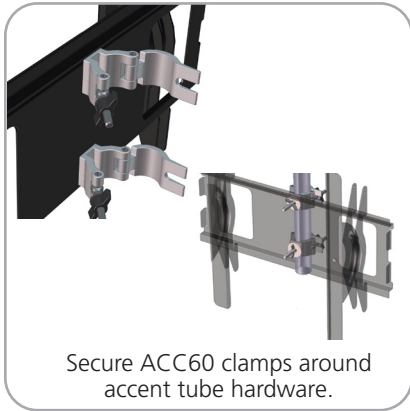

STEP 7: ATTACH COUNTER TO ACCENT FRAME

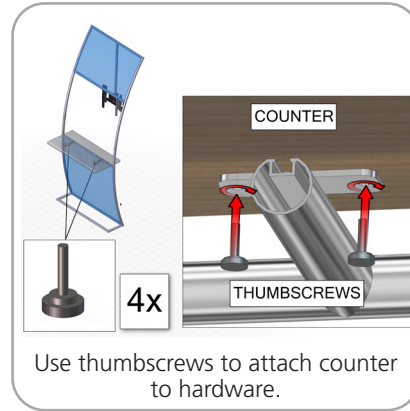

STEP 8: ATTACH TO BACKWALL WITH CLAMPS

