

Formulate Designer Series 10' Backwall - Kit 09

FMLT-DS-10-09

Formulate™ Designer Series 10ft displays have unique stylistic features and shapes, are portable and easy to assemble. The aluminum tube frame features snap-buttons and/ or spigot connectors and zipper pillowcase fabric graphics. All displays come in portable, wheeled transit cases. Simply pull the pillowcase fabric graphic(s) over the frame and zip.



features and benefits:

- Premium aluminum tube frames with snap button/ spigot assembly
- Easy to store and ship
- Quick to set up
- Weighted feet for added stability
- Two zipper pillowcase fabric graphics
- Kit includes: monitor kiosk featuring a medium monitor mount, can hold 40-50" monitor/ max weight 75lbs
- Lifetime limited hardware warranty against manufacturer defects

dimensions:

Hardware	Graphic
<p>Assembled unit: 117.49" w x 98.32" h x 36.07" d 2984.21mm(w) x 2497.38mm(h) x 916.3mm(d)</p> <p>Approximate weight with cases: 150 lbs / 68 kgs</p>	<p>Please be sure to include a 2" bleed around the perimeter.</p> <p>Refer to related graphic template for more information.</p> <p>Visit: www.exhibitors-handbook.com/graphic-templates</p>
Shipping	
<p>Packing case(s): 2 OCE Cases</p> <p>Shipping dimensions: 16.75" w x 64.25" h x 16.88" d 425.5mm(w) x 1632mm(h) x 428.8mm(d)</p> <p>Approximate total shipping weight (includes cases & graphics): 162 lbs / 73.5 kgs</p>	

additional information:

Graphic material:
dye-sublimation zipper pillowcase fabric

We are continually improving and modifying our product range and reserve the right to vary the specifications without prior notice. All dimensions and weights quoted are approximate and we accept no responsibility for variance. E&OE. See Graphic Templates for graphic bleed specifications.

Included In Your Kit

Tools, Components, & Connectors



ALLEN KEY SET x1

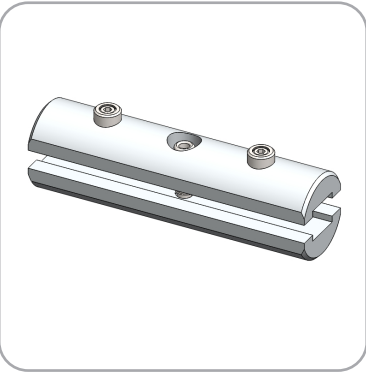

ES30 x9

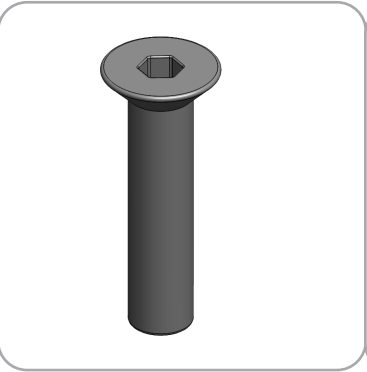

LN114-SCRW x1

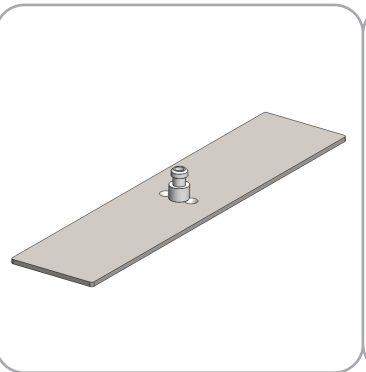

STABILIZING BASE A x1

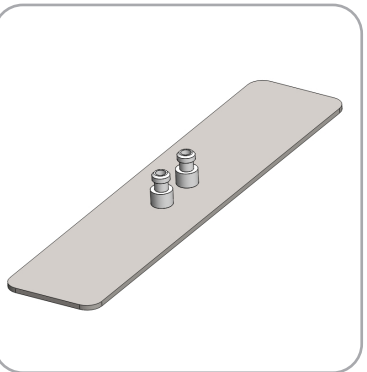

STABILIZING BASE B-2 x1

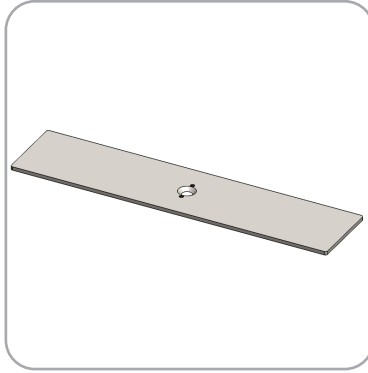

LN114-S2-450 x1

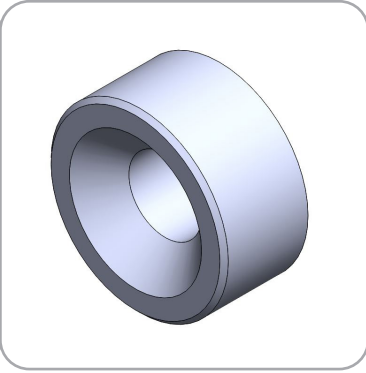

M10 INSERT x1



TCH-30 x2

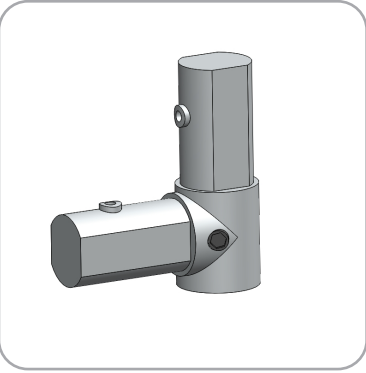

ES30-90B x3

Graphics

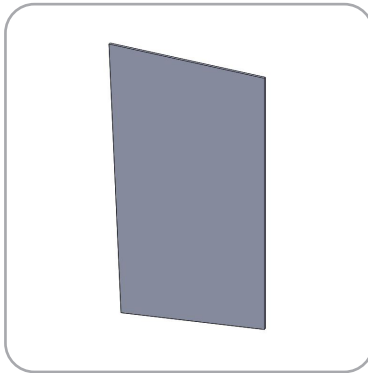

FMLT-DS-10-09-A-G x1

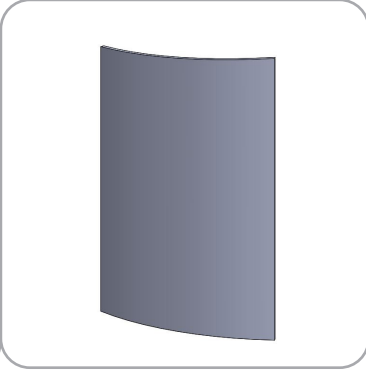

FMLT-DS-10-09-B-G x1

Included In Your Kit

Tubes

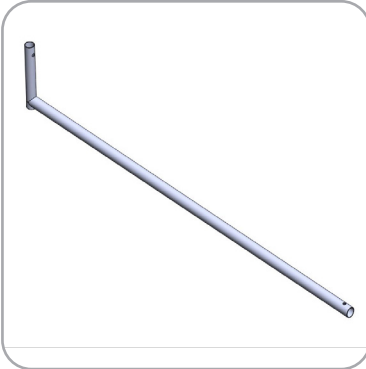

DS-10-03-A-T1 x1



DS-10-03-A-T2 x1

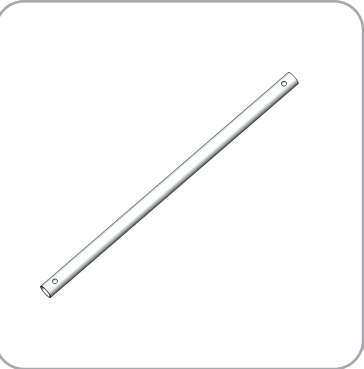

DS-10-03-A-T3 x4

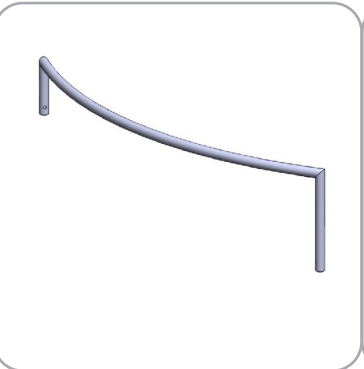

DS-10-03-B-T1 x1

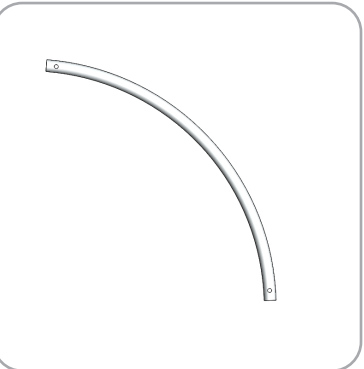

DS-10-03-B-T2 x1

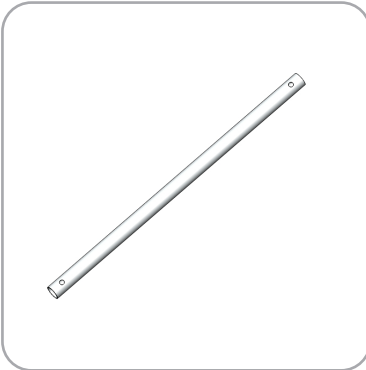

DS-10-03-B-T3 x4

PART CODE	QTY	DESCRIPTION
DS-10-09-A-T1<As Machined>	1	30MM BOTTOM TUBE FOR DS-10-09-A
DS-10-09-A-T2	1	30MM TOP TUBE FOR DS-10-09-A
DS-10-09-A-T3	4	30MM SIDE TUBE FOR DS-10-09-A
DS-10-09-B-T1<As Machined>	1	30MM TOP TUBE FOR DS-10-09-B
DS-10-09-B-T2	1	30MM BOTTOM TUBE FOR DS-10-09-B
DS-10-09-B-T3	4	30MM SIDE TUBE FOR DS-10-09-B
ES-30	9	EXPANDING SPIGOT FOR 30MM TUBE
ES30-90B	3	30MM CORNER CONNECTOR WITH M10 INSERT
TCH-30	2	30MM FABRIC CLAMP
LN114-S2-450	2	LINEAR FOOT WITH COUNTERSUNK HOLES
LN114-S3	1	LINEAR FOOT FOR TWO FRAMES, 450MM X 100MM X 5MM
LN114-SCRW	4	M10X45MM SOCKET FLAT CAP SCREW, BLACK FINISH ALLOY STEEL
M10 INSERT FOR 30MM TUBE	1	M10 INSERT FOR 30MM TUBE
DS-10-09-A-FABRIC COVER	1	FABRIC COVER FOR DS-10-09-A
DS-10-09-B-FABRIC COVER	1	FABRIC COVER FOR DS-10-09-B

Please note: Assembly for monitor mount start on page 8

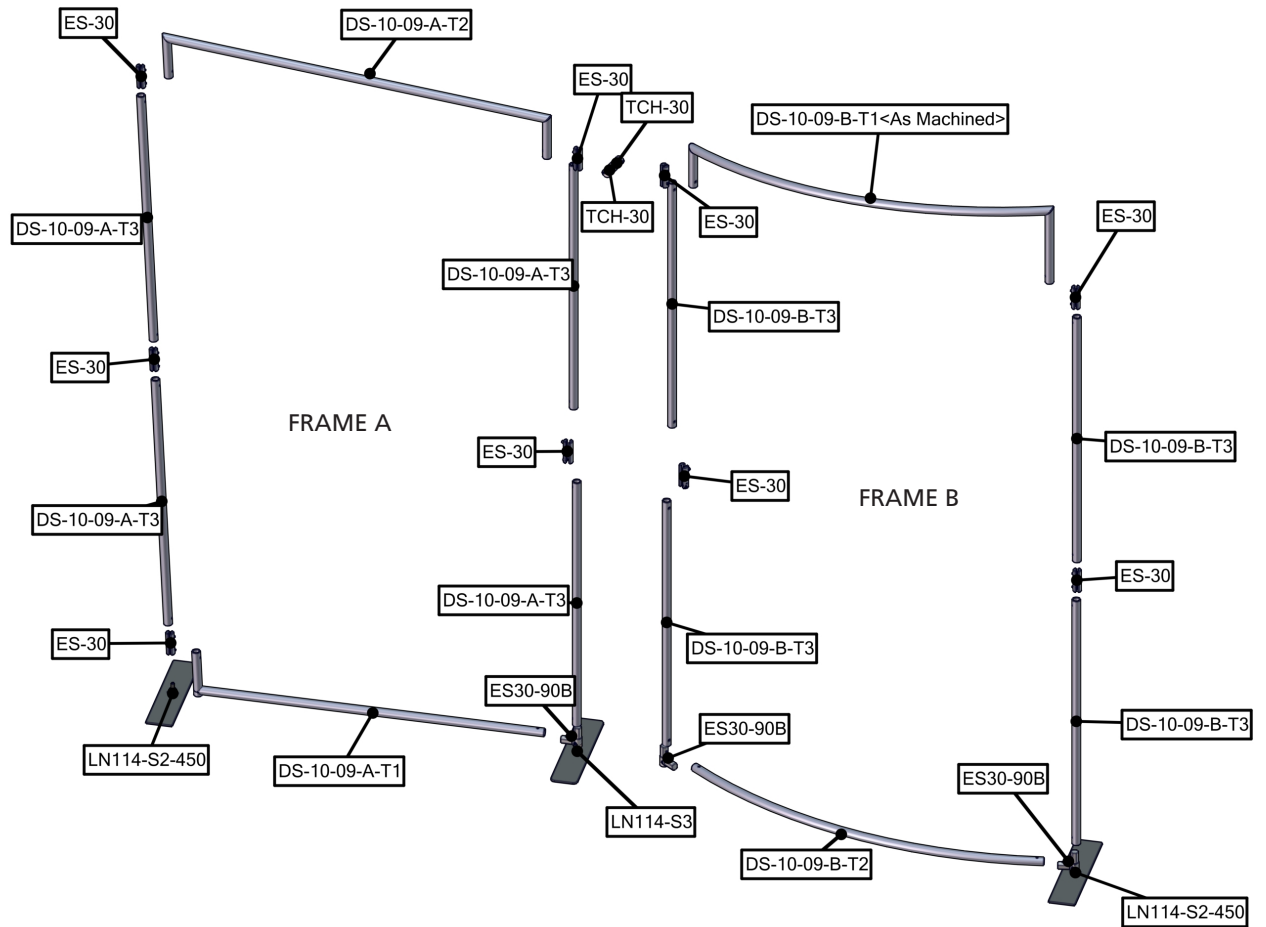

Labeling Diagram

FMLT-DS-10-09

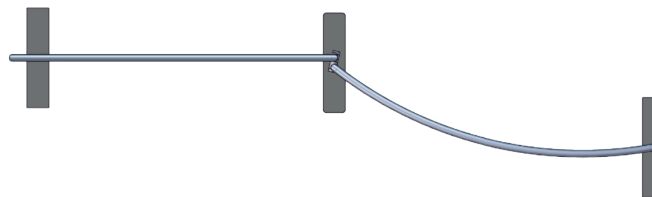
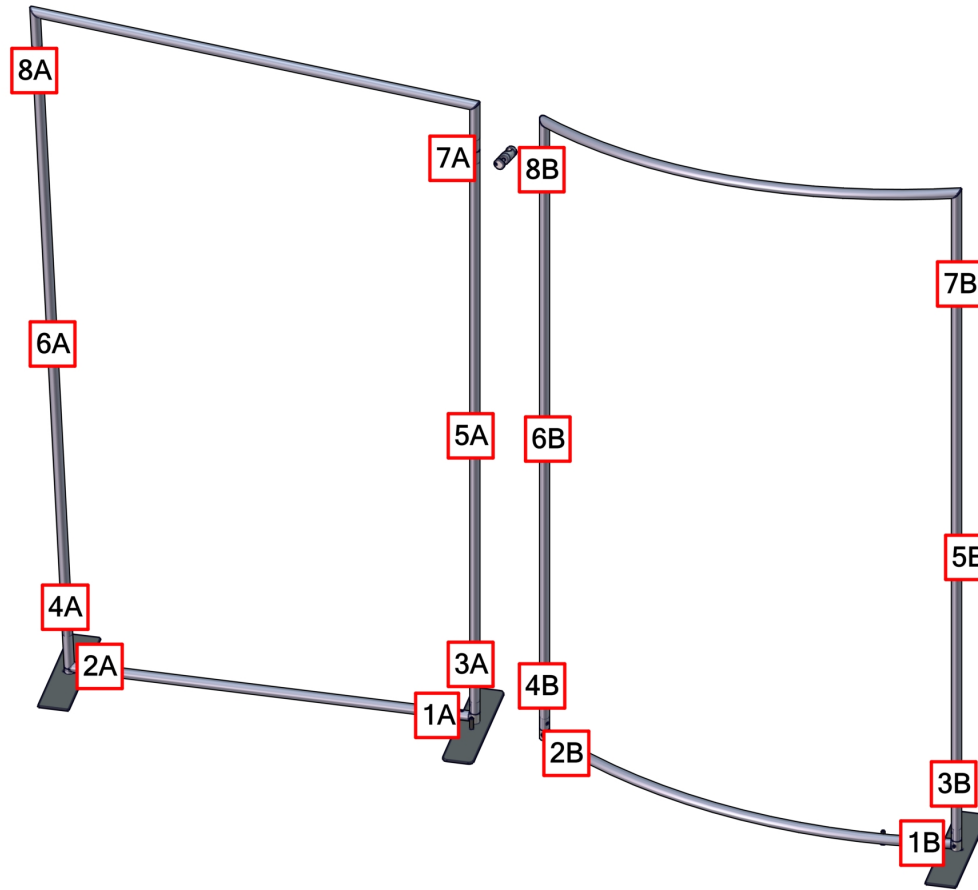
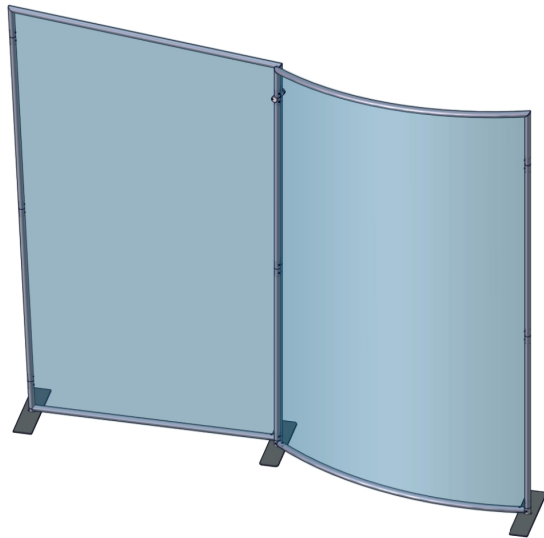

OVERHEAD VIEW

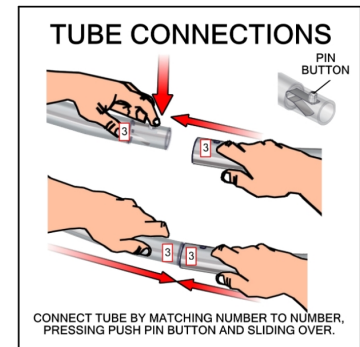

Kit Assembly

Step by Step

Step 1.

Gather the components necessary for assembling frame A and lay them flat on the floor. Assemble in the order the "Labeling Diagram" instructs. Lock your connectors into place using the provided allen key set.

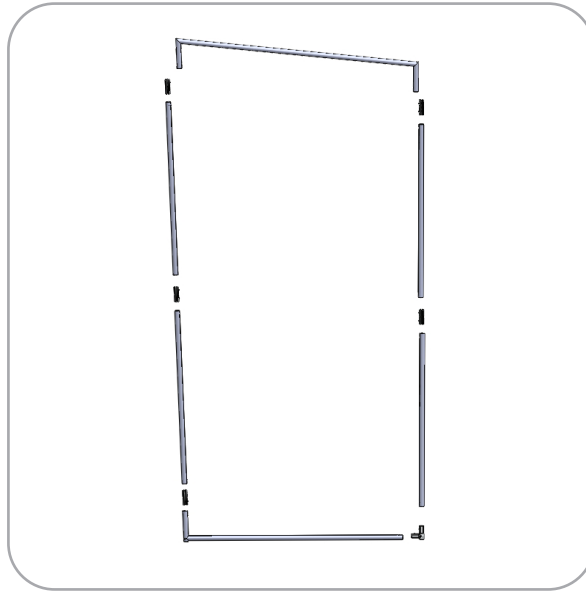

Step 3.

With frame A laying flat on the floor, locate your pillowcase A graphic. With the pillowcase unzipped, encase frame A by covering the frame from top to bottom.

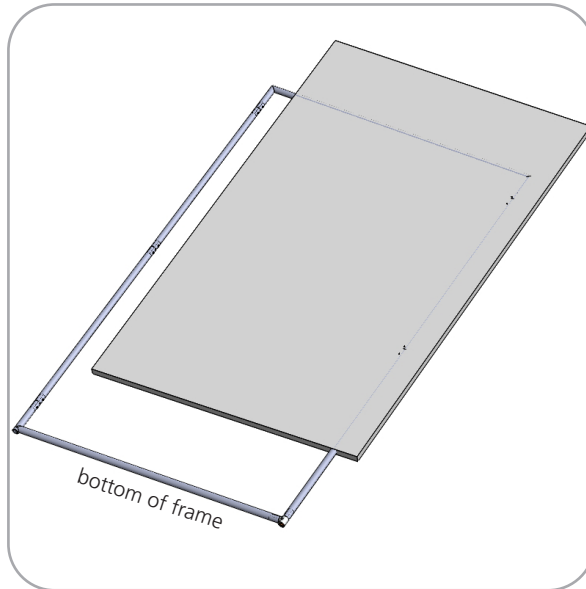
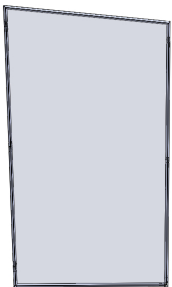

Step 2.

Gather the components necessary for assembling frame B and lay them flat on the floor. Assemble in the order the "Labeling Diagram" instructs. Lock your connectors into place using the provided allen key set.

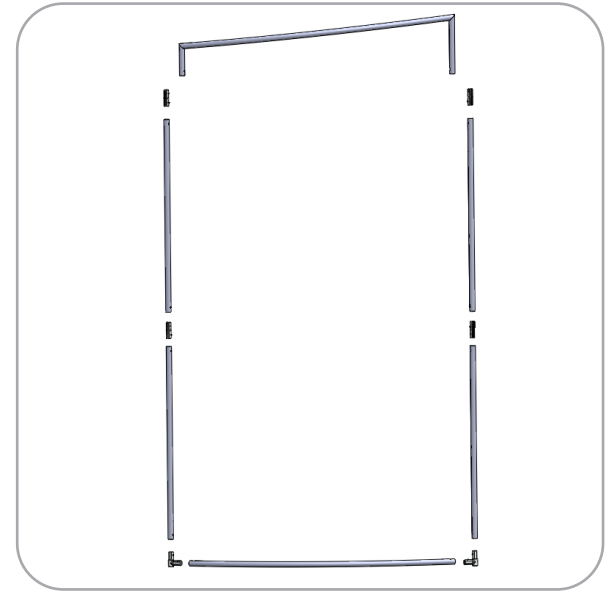
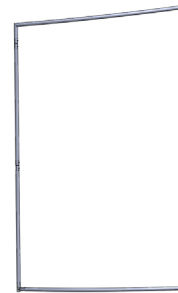

Step 4.

With frame B laying flat on the floor, locate your pillowcase B graphic. With the pillowcase unzipped, encase frame B by covering the frame from top to bottom.

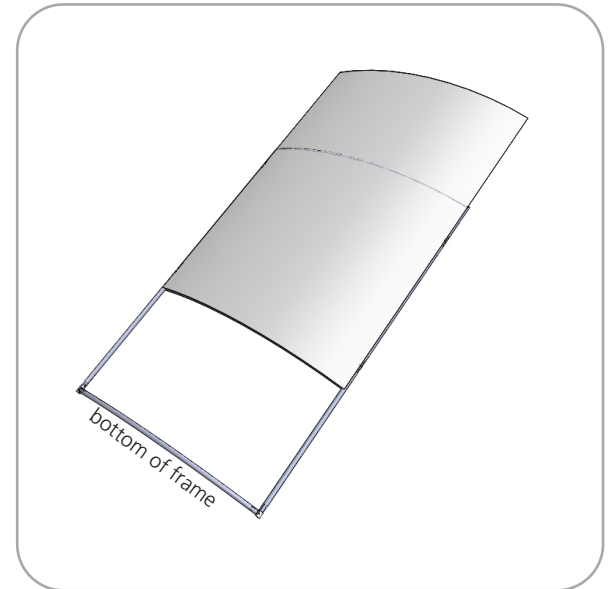

Kit Assembly

Step by Step

Step 5.

Gather the LN114-S2-450, and LN114 Screw. Attach the base to Frame A by screwing the LN114 screw through the base and M10 spacer as shown in the image to the right.

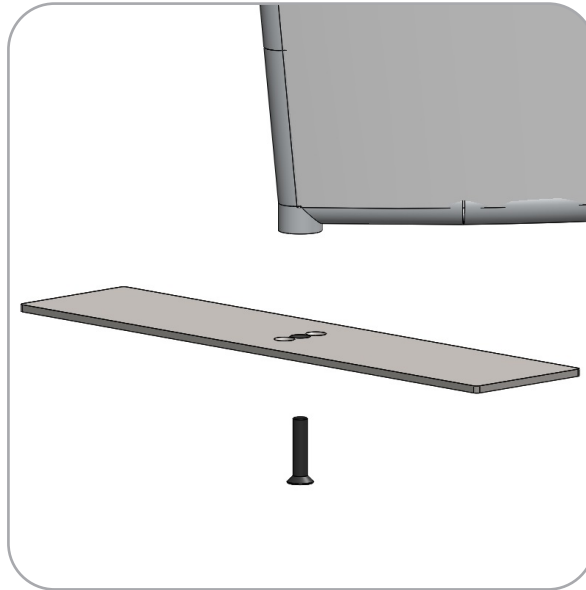
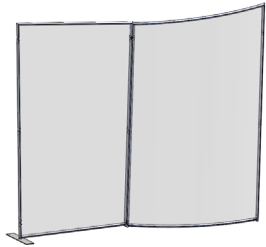

Step 6.

Locate your Stabilizing Base A. Insert the hub into the bottom of the ES30-90B. Tighten into place with the screw located on the side of the ES30-90B.

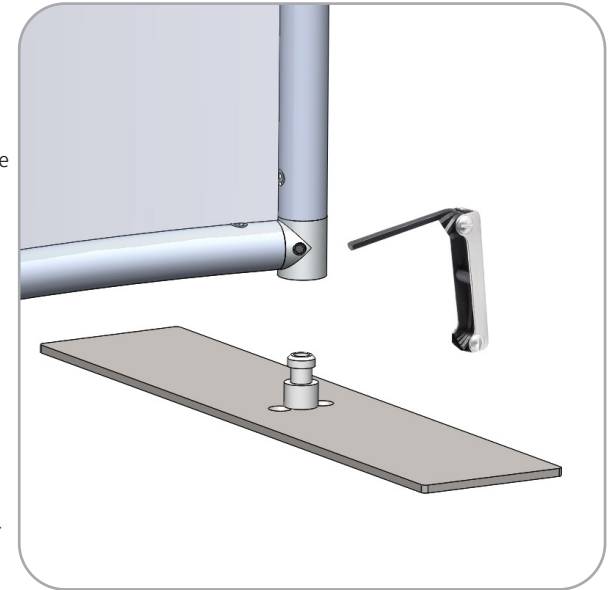
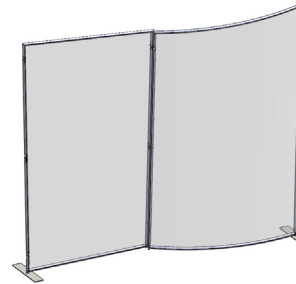

Step 7.

Locate your Stabilizing Base B-2. Insert the hubs into the ES30-90B of Frames A and B. Tighten into place using the lock screws located on the side of the ES30-90Bs.

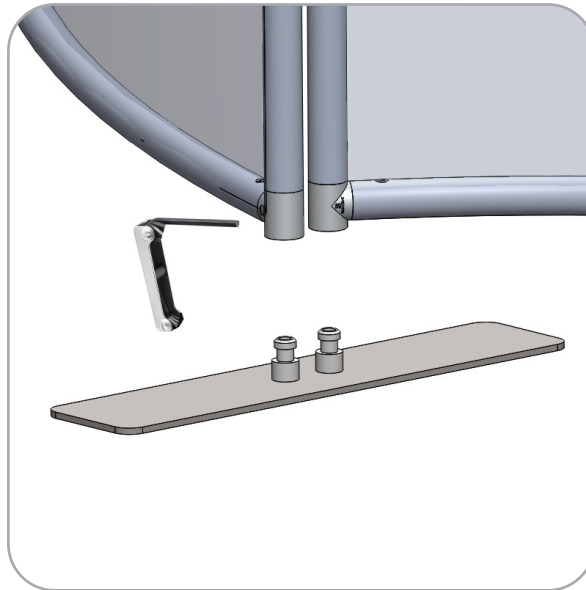
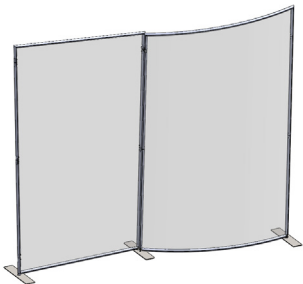

Step 8.

Use both TCH-30 to combine both frames. Tighten on each side of the frame as shown in the image to the right.

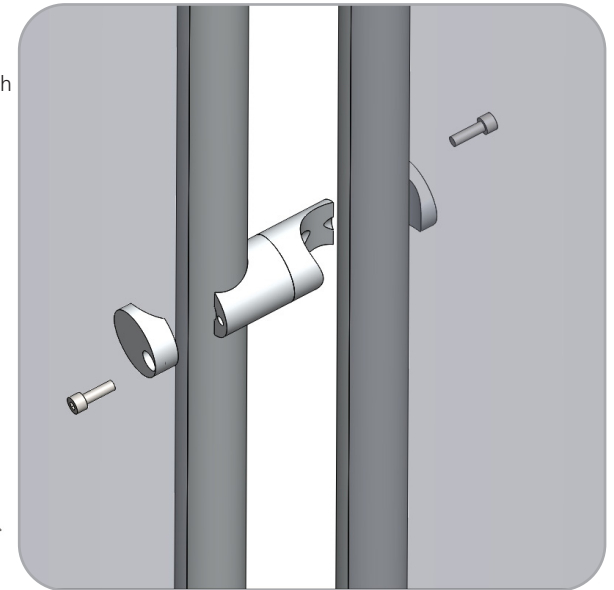
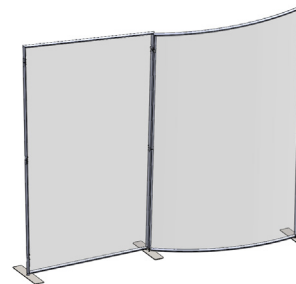

Included In Your Kit

Tools, Components, & Connectors



ALLEN KEY SET x1



LM-MB x1

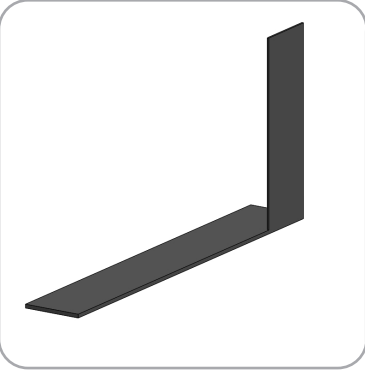

PM453-MM-FOOT-L x1

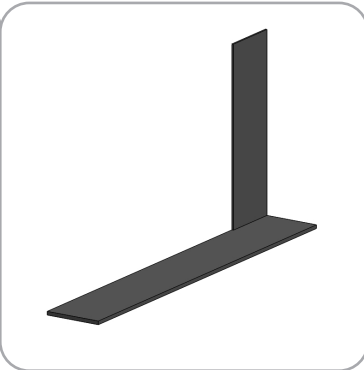

PM453-MM-FOOT-R x1



LN100 x4

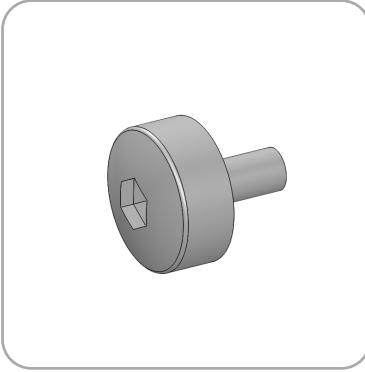

M5 THUMBSCREW x8



PH2-300-TG

Included In Your Kit

Tubes



PH2-350-L-L x2



PH-350-L-L x1

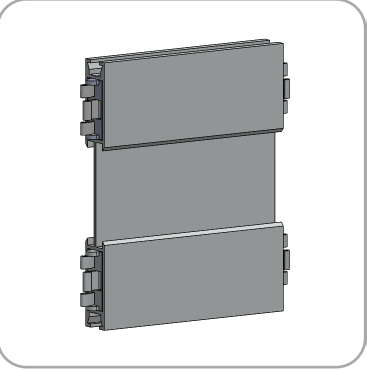

PH5-100-L-L x2

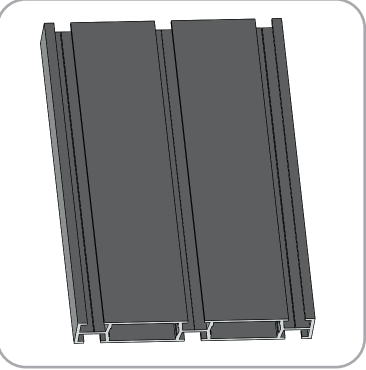

PM4S4-150 x2

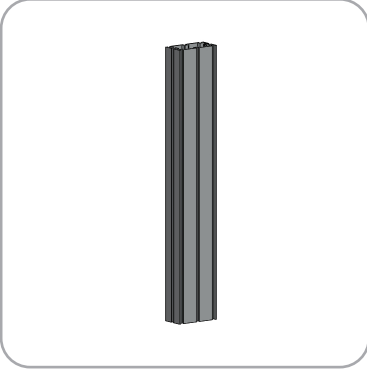

PM4S3-600-A165-A165 x2



PM4S3-1200-A165-A165 x2

PART CODE	QTY	DESCRIPTION
PH-350-L-L	1	350MM LENGTH OF PH EXTRUSION-WITH CAM LOCKS BOTH ENDS
PH2-350-L-L	2	350MM LENGTH OF PH2 EXTRUSION-WITH CAM LOCKS BOTH ENDS
PH5-100-L-L	2	100MM LENGTH OF PH5 EXTRUSION-WITH CAM LOCKS BOTH ENDS
PM4S4-150	2	150MM LENGTH OF PM4S4 EXTRUSION
PM4S3-1200-A165-A165	2	1200MM LENGTH OF PM4S3 EXTRUSION-WITH STOPS BOTH ENDS
PM4S3-600-A165-A165	2	600MM LENGTH OF PM4S3 EXTRUSION-WITH STOPS BOTH ENDS
PH2-300-TG	2	300MM LENGTH OF PH2 EXTRUSION WITH TENSION GLIDES
SW-FOOT-650A-R	1	PM4S3 MONITOR MOUNT FOOT, RIGHT
SW-FOOT-650A-L	1	PM4S3 MONITOR MOUNT FOOT, LEFT
LM-MB	1	LARGE MONITOR MOUNTING BRACKET FOR LARGE SIZE (32"-70") FLAT PANEL LCD
5MM ALLEN-T	1	5MM "T" ALLEN KEY TOOL, RED HANDLE
INSTRUCTIONS	1	SETUP INSTRUCTIONS
OCE	1	EXPANDING PLASTIC CASE

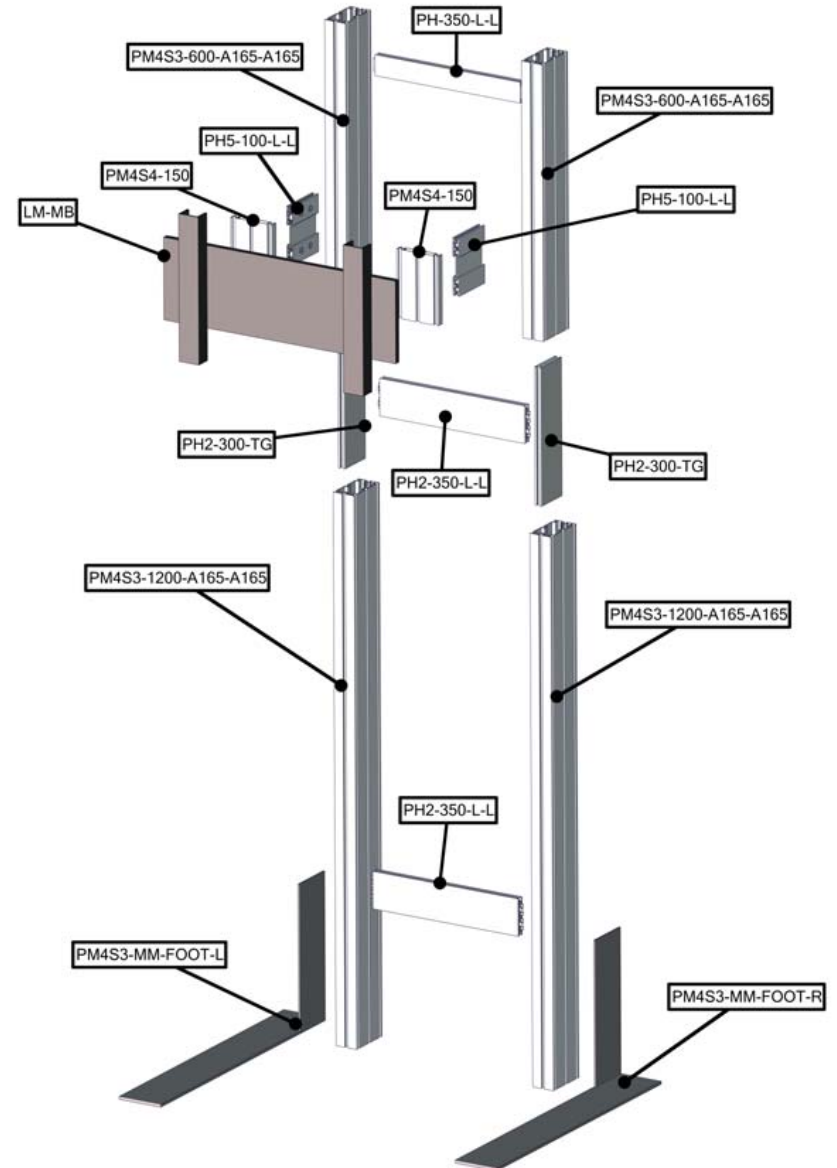

Kit Assembly

Step by Step

Step 1.

Locate your PM4S3-600, PM4S3-1200, and PH2-300-TG extrusions. Place the PH2 into one side of the PM4S3-1200 so that it goes as deep as the internal pins. Connect the PM4S3-600 by sliding it over the PH2. Repeat for the other side.

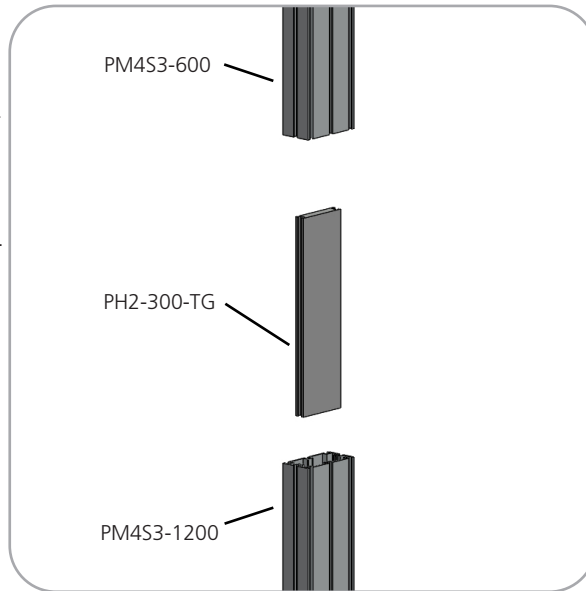

Step 2.

Collect your PH-350 and both PH2-350 extrusions. Lock the extrusions into the back channel of the three channel PM4S3 faces as shown in the images figures. Be sure the locks face toward the back of the assembly.

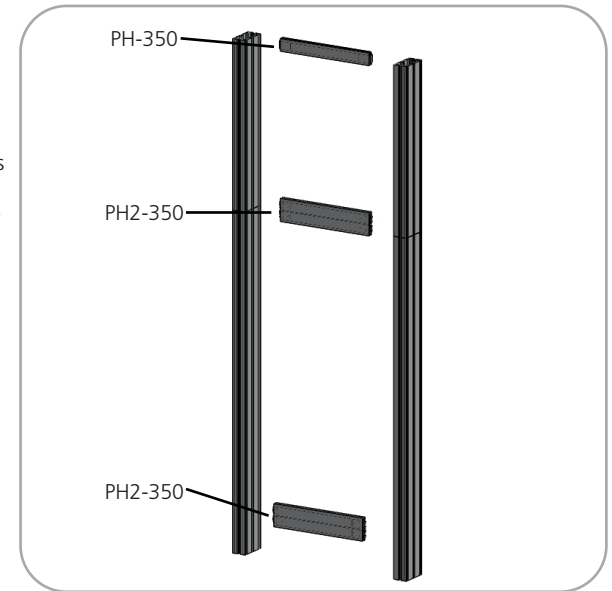
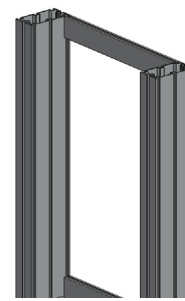

Step 3.

Locate your your M5 thumbscrews, LN100s, and both PM4S3-MM Feet. Slide the LN100s into the middle channel of the PM4S3. Screw your M5 thumbscrews through the base and into the LN100 holes as shown in the figure right.

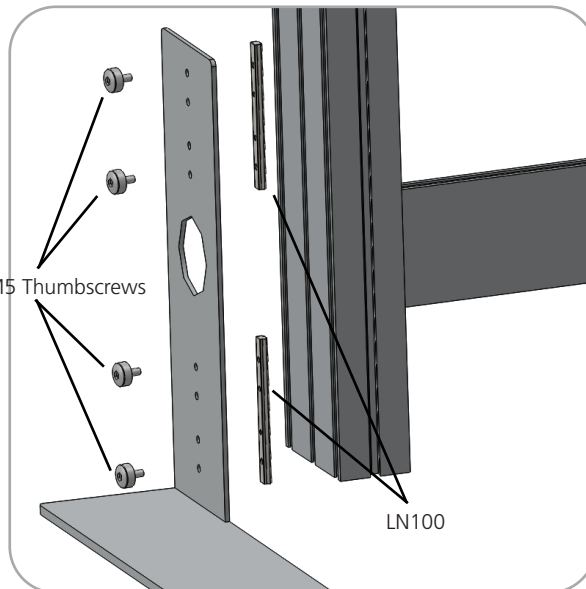
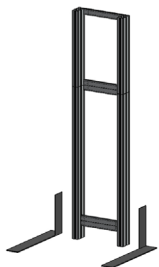

Step 4.

Measure from the ground to the center of the hole in your main kit's graphic. Lock the center of your PH5 into the PM4S3 stacks at the height you collected.

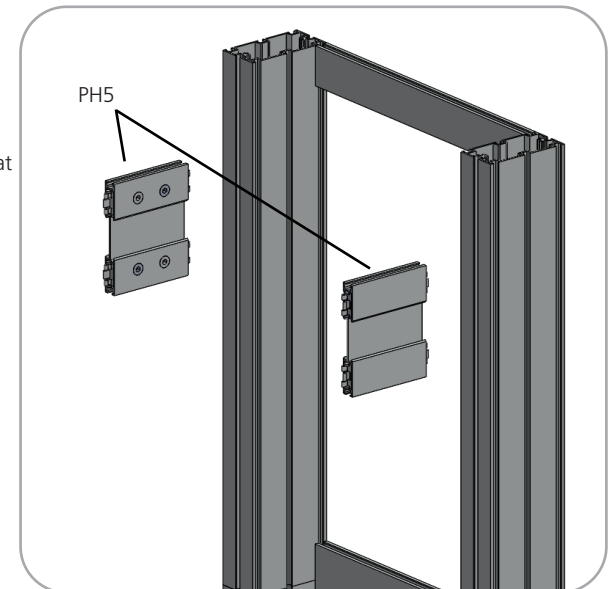

Kit Assembly

Step by Step

Step 5.

Lock your PM4S4 to ends of your PH5.

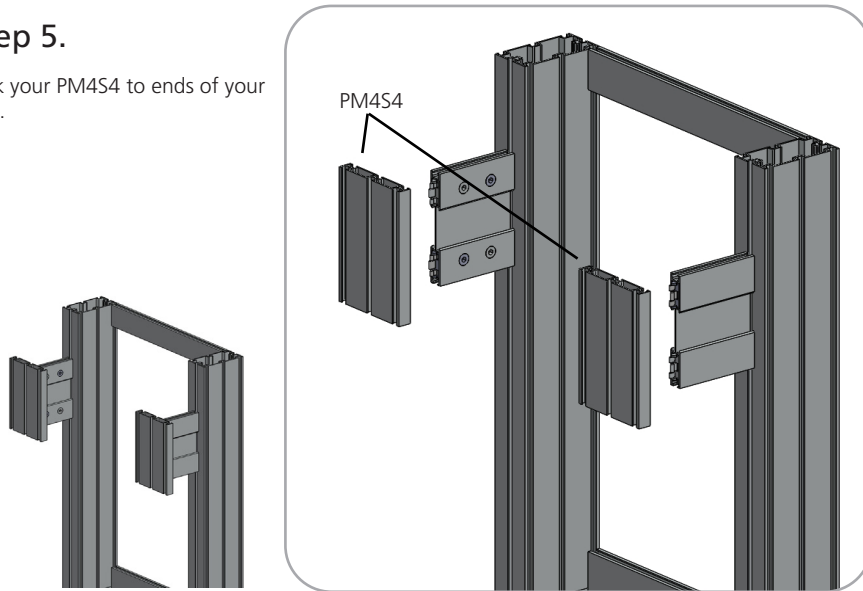

Step 6.

NOTE: Your main backwall assembly must be completed with graphics before completing this step of the monitor kit.
Set your monitor stand so that the extrusion arms fit through the graphic hole. Use the provided wingnuts and washers with the detail below to complete your monitor stand, sandwiching the graphic.

